

Step-by-step

Please follow these steps...

The assembly of the *crawlster*[®]4Wd steering system on Vanquish Products WRAITH Tuning Knuckles

VPS03201

Reserve technical changes.

crawlster[®] is DPMA protected. All rights reserved.
Reproduction / distribution – even in part –
only with express permission.

crawlster[®]4Wd VP

The **WRAITH** dimension steering system.



Step 1

Preparation



Dismantling of the complete front axle, wheels, steering and steering linkage, damper & servo connectors, servos themselves, knuckles, C-hubs, and upper and lower links...

Step 2

Preparation



Make a small indentation of about 4 mm (from front right) in the central ridge of the differential housing

Step 3

Preparation

AX80018**

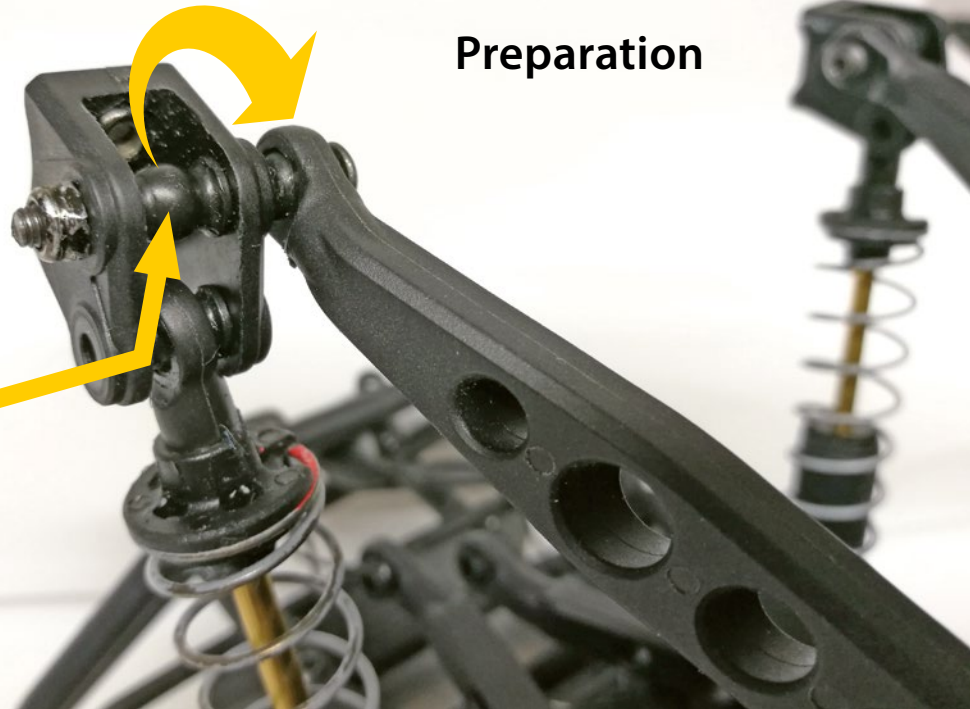
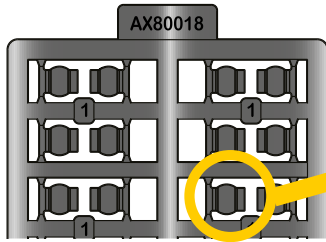

- * incl. in crawlster®4Wd set
- ** incl. Axial RTR/KIT

Remounting the front / bottom link inwards,
with flathead screw M3x25* (from inside), spacer AX80018** in between
and locking nut M3** (outside) to achieve the necessary larger steering
angle on the inside wheel

Step 4

Steering System

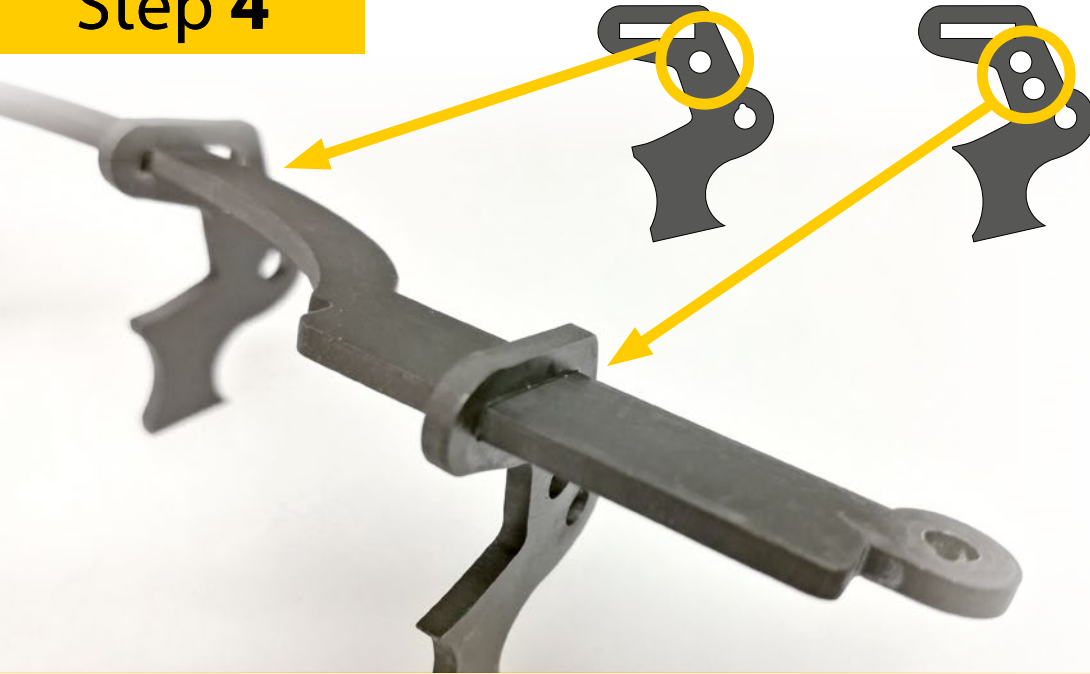

- Slide 2 steering bearings on the steering bracket** from right to left
- first the bearing with 1 mark,
 - then the one with 2 marks

Step 5

Steering System

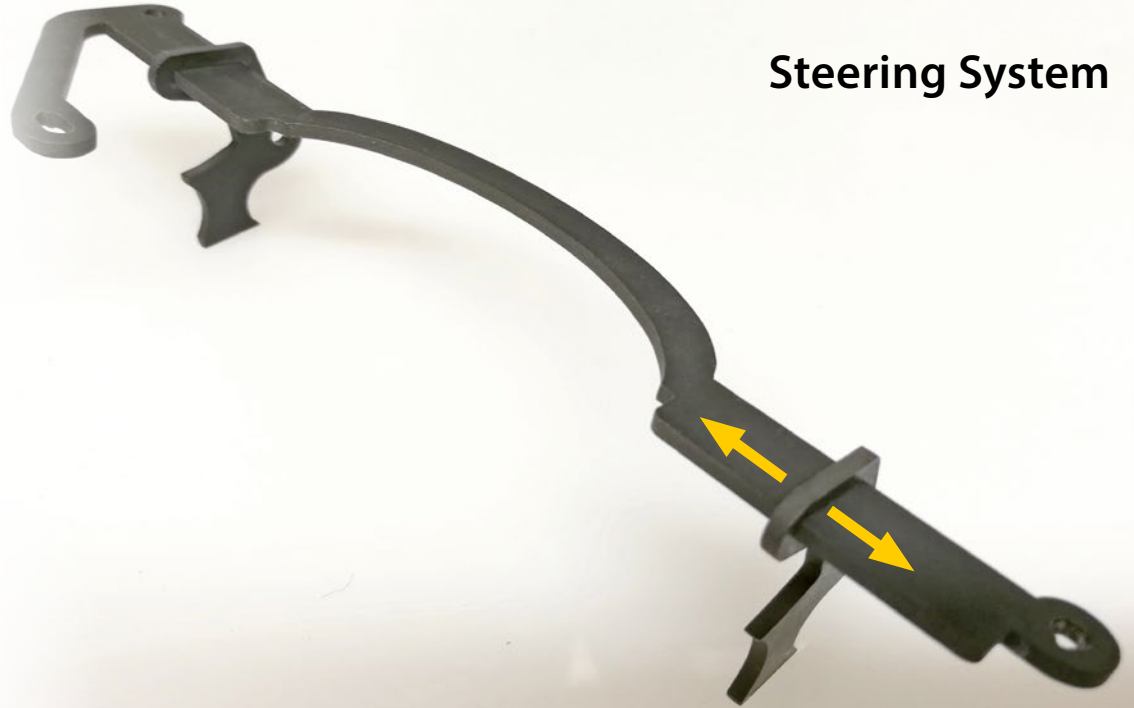

CAUTION

Perfect sliding arises only with Step 13 !

Step 6



** incl. Axial RTR/KIT

Loosely preassemble the two steering bearings of the assembled crawlster®4Wd steering system with existing pan head screws M3x20** to the damper housings.....

Step 7

Steering System

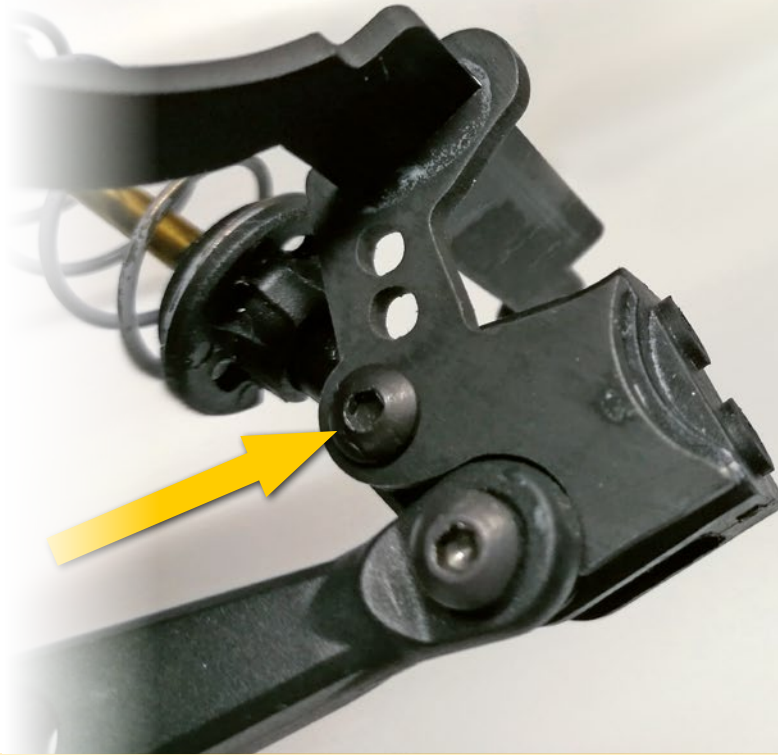

** incl. Axial RTR/KIT

.....“from the inside through the shock absorbers to the outside”
with locknut M3**

Step 8

Axle / Knuckles

select **1st notch**

- Axial plastic C-hubs
- Vanquish aluminum C-Hubs

select **2nd notch**

- Axial aluminum C-Hubs



Positioning / fixing the C-hubs



CAUTION

Step 9

Axle / Knuckles

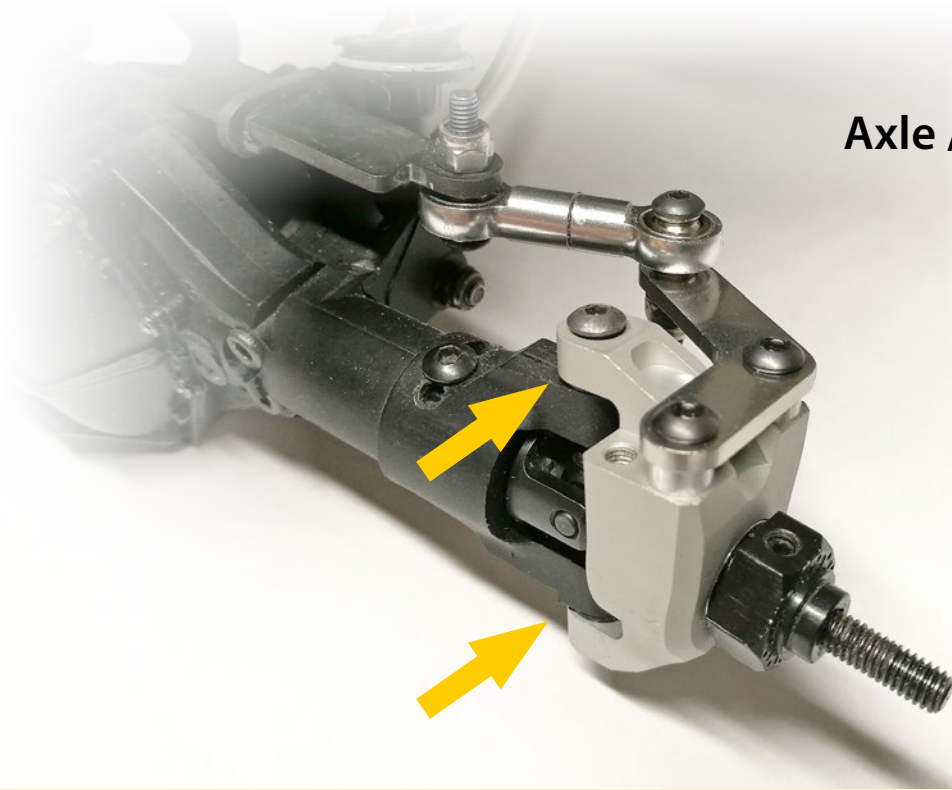

**Mount each VP-knuckle right / left
on the C-hub carrier.**

Step 10

Axle / Knuckles

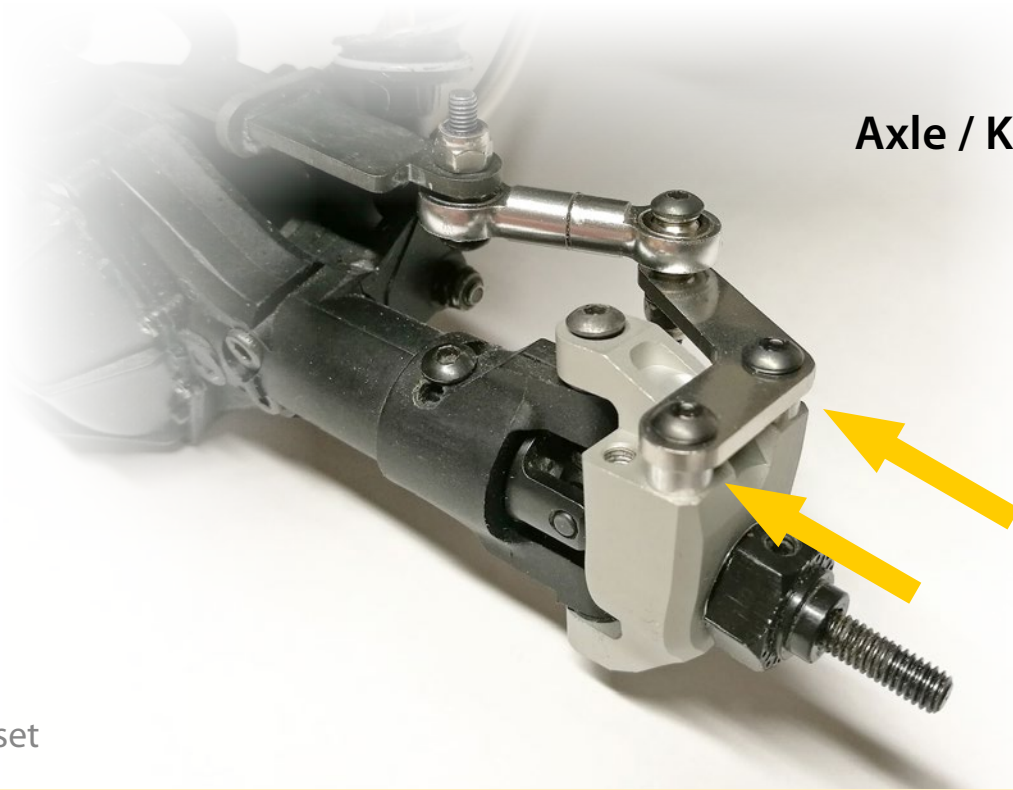

* crawlster®4Wd-VP set

Screw crawlster®4Wd-VP knuckle links
with each of the 2 x 3 mm* spacer sleeves
with M3x10* pan head screws onto the VP-Knuckles (VPS03201)

Step 11

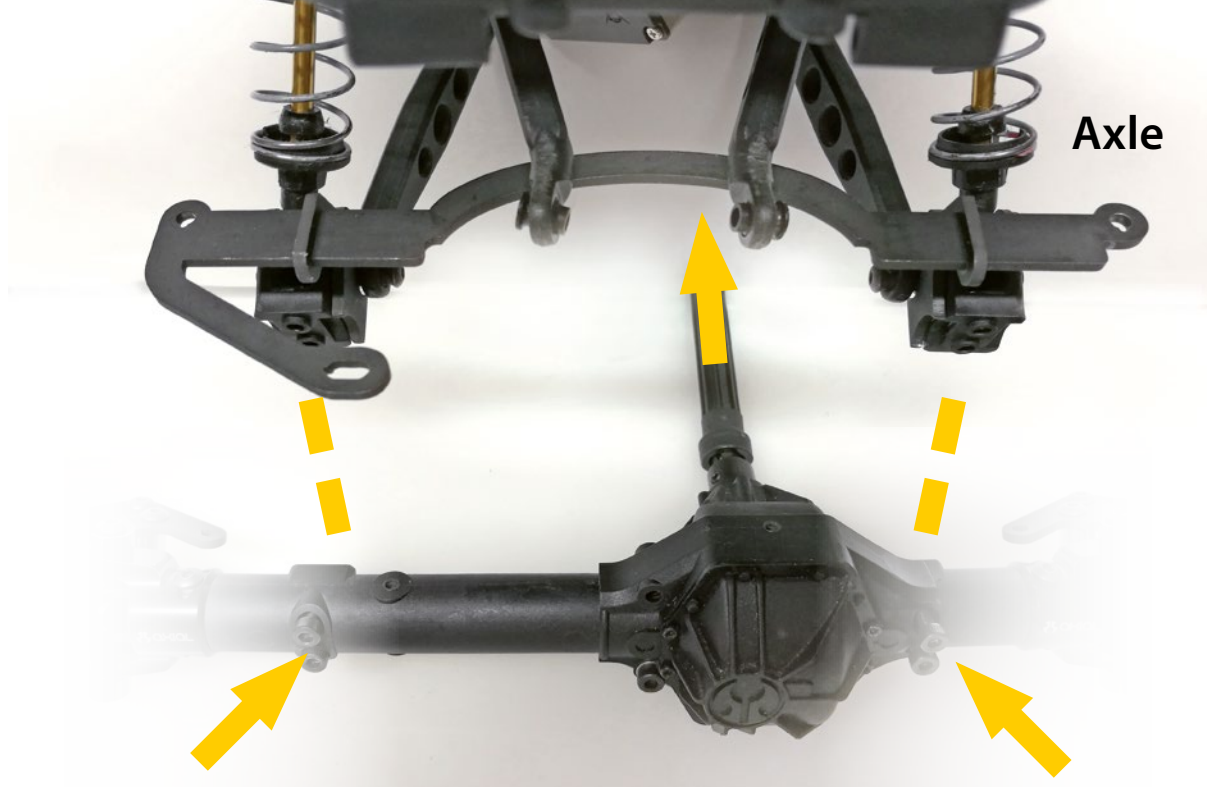

Take the axle with the exchanged knuckles and crawlster®4Wd-VP knuckle links **and fix them** onto the shock-absorber connectors which have been prepared with the steering system. *Remember assembling the drive shaft !*

Step 12

AX80057**

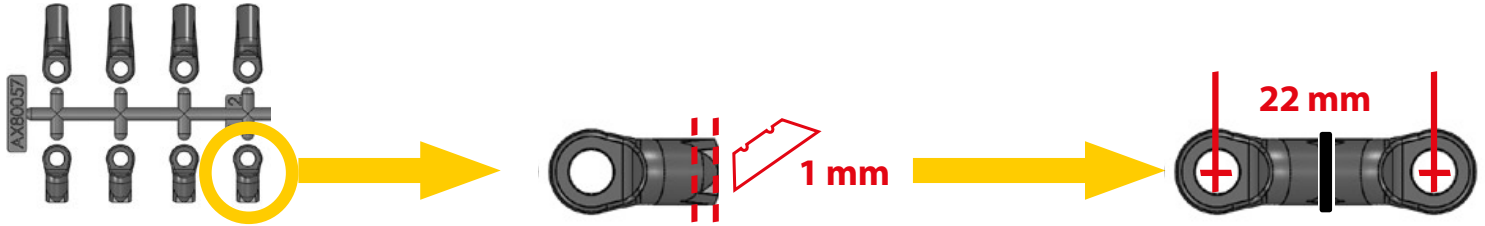

Make sure of equal dimensioning / total length
when using aluminum/steel rod ends

* crawlster®4Wd set
** incl. Axial RTR/KIT

Prepare 2 tie rods from 2 x short rod ends (from AX80057)** , shorten by 1 mm, connect with the 12 mm* threaded pin + O ring* and screw together giving a total length (eye-to-eye) of exactly **22 mm**

Step 13

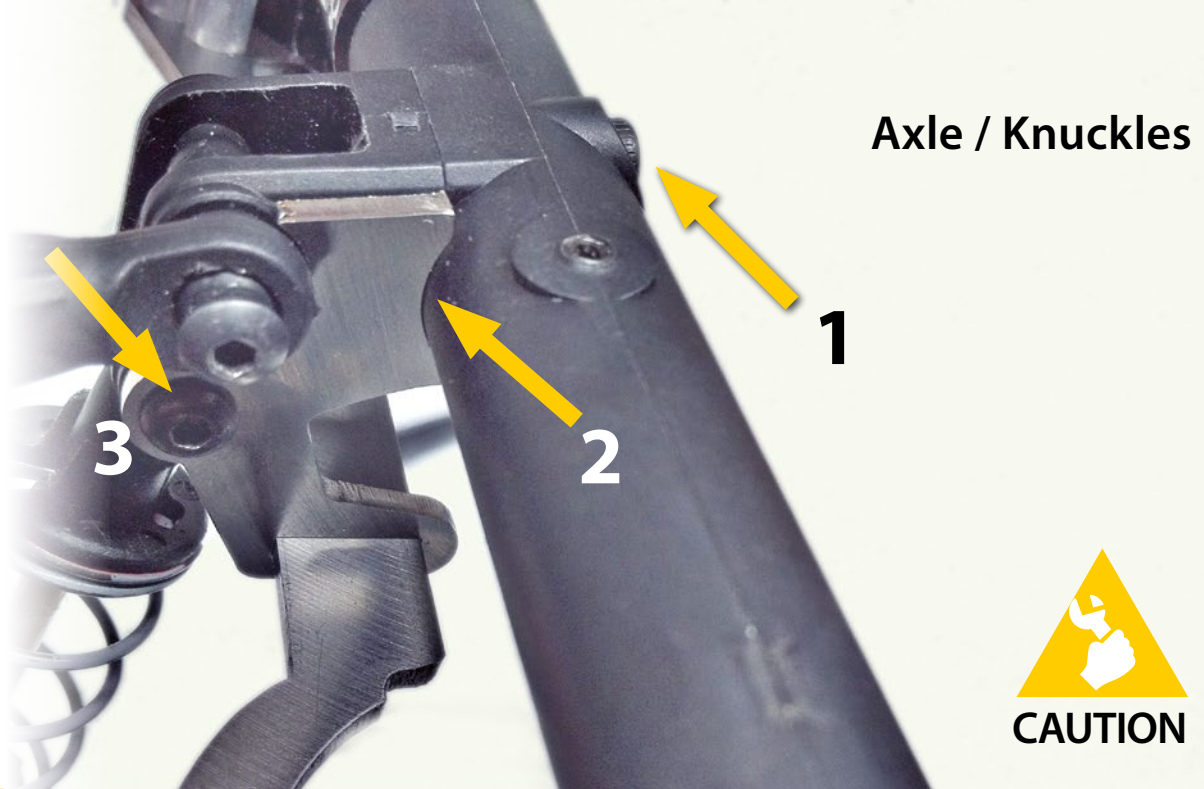

Ensure that the steering bearings **fit seamlessly** when tightening the 4 front screws (1) **to the axle (2)** and align parallel. ***Then firmly tighten the screw (3)***

Step 14

Mounting

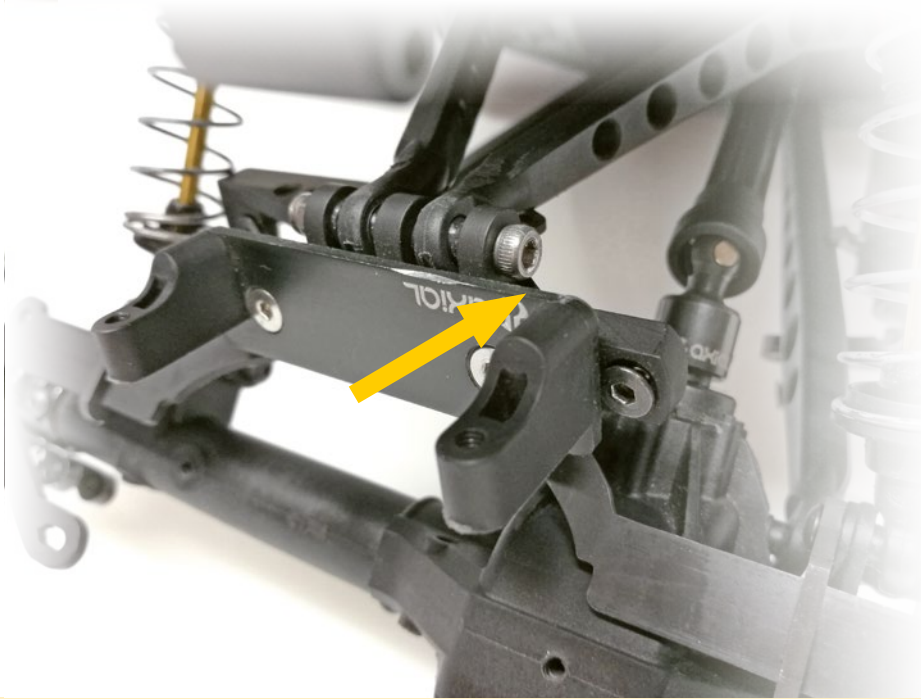

Fix the front upper links to the servo mount...

Step 15

Mounting

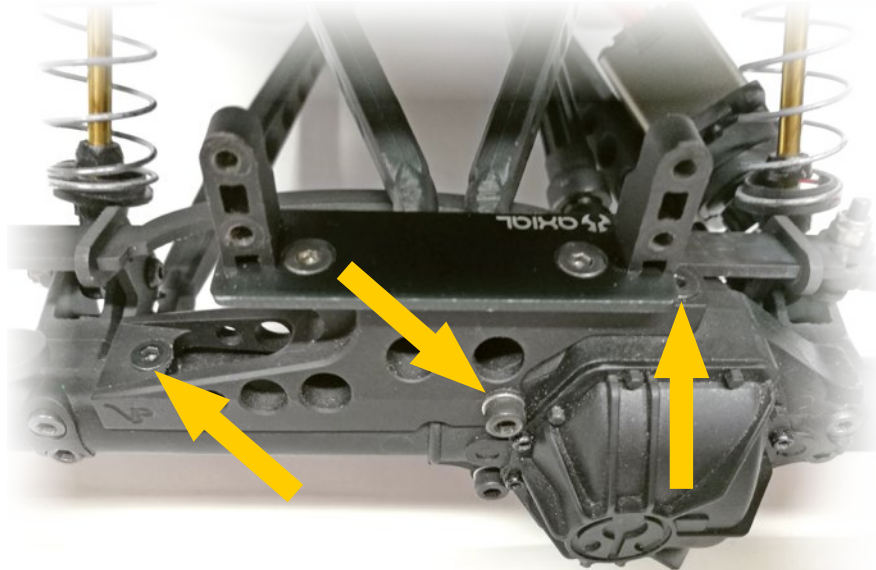

...and fix the servo mount onto the prepared axle

Step 16

Mounting

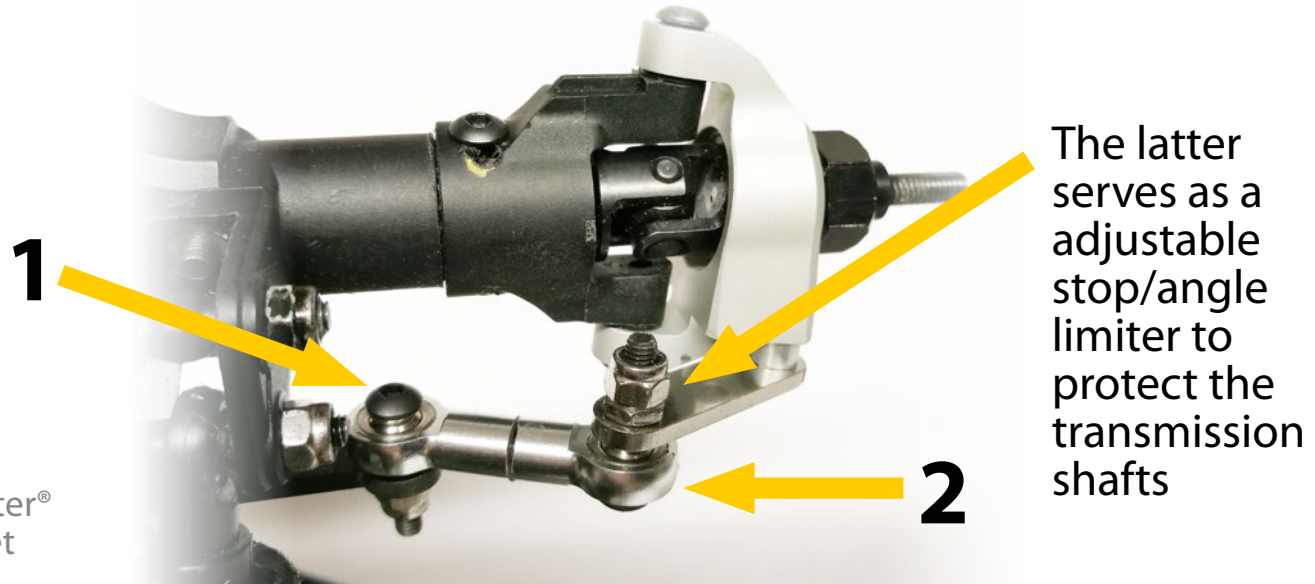

* crawlster®
4Wd set

Tightly screw the **hinged brackets** with M3x15* flathead screw from below **(1)** onto the steering bracket – lock with lock nut M3* – and on the knuckle links with screw M3x15* from above (2); tighten with conternut* plus locknut* below.

crawlster®4Wd-VP

Step 17

Mounting



Grease all moving parts of the crawlster®4Wd steering system carefully and sparingly **with a high quality silicone grease**

Step 18

Mounting

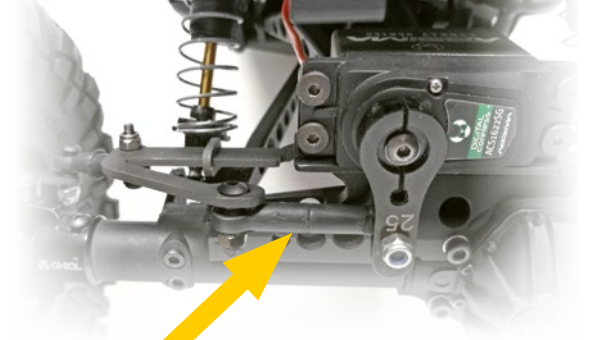

Mount the **steering servo** rotated 180° degrees – servo axis „left“ (viewed from the front)

Servo horn 20 mm – in the case of aluminum – possibly sand on the back to ensure sufficient freedom of movement

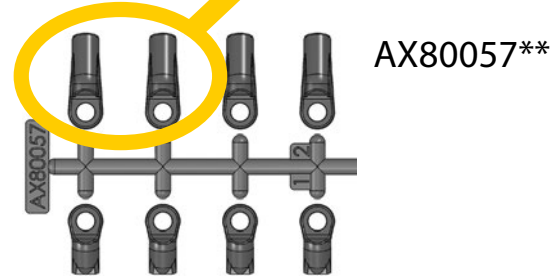

- * crawlster®4Wd set
- ** incl. Axial RTR/KIT

Assemble the servo linkage using 2 x long rod ends (of AX80057)** connect with threaded 12 mm* pin and screw together

Step 19

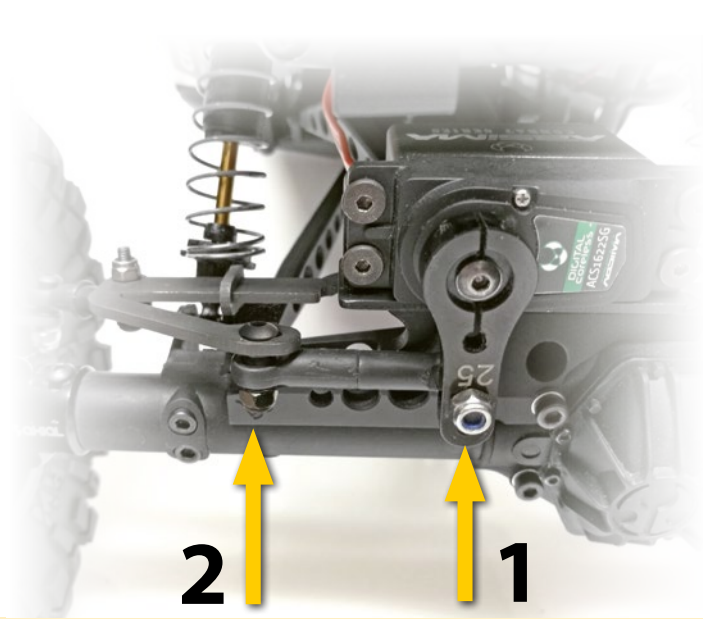

linkage

Servo-Position

electrically (0%)
and mechanically
set to neutral

**Reverse movement
direction** of the
steering servo at the
transmitter if necessary

- * crawlster®4Wd set
- ** incl. Axial RTR/KIT

Fix the articulation on the Servo from behind **(1)**
and on the steering bracket from above **(2)**,
each with 1 flathead screw M3x16* + lock nut M3*

...done !

crawlster®4Wd

The WRAITH dimension steering system.



If the crawlster®4Wd steering system has been properly assembled and the transmitter is set at 100%, the wheels should have reached their limit of movement, ie. the inner wheel should have stopped a few mm from the front/bottom links, the outer wheel on the stop of the front steering arms. Slightly adjust the movement limits if necessary.